

# ENVIROGRAF® PRODUCT 113

## COATED QUILT SLEEVING

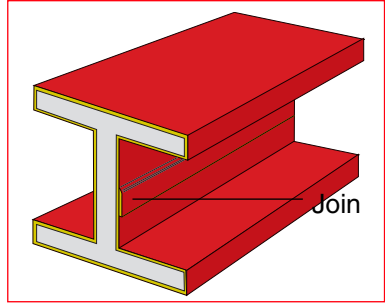
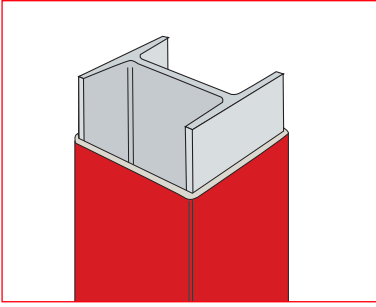

### DESCRIPTION

This is a 9mm thick flexible sheet material with an intumescent coating, for the protection of steel construction items.

### USE

Wrap around steel, using the supplied Envirograf® Product 46 (intumescent adhesive) for adhesion. At walls or joints of the Envirograf® Product 113 material on the steel, an overlap of 50mm is required, as depicted in the illustration above right.

### PERFORMANCE

Tested on steel in accordance with the general principles and criteria of BS476 Part 20 (1987), achieving 87 minutes of integrity.

### ORDERING REFERENCES:

**CQS** State dimensions of material required

